



**BONN HUNGARY
ELECTRONICS**

**900 MHz GSM
BANDSELECTIVE
MINI-REPEATER**

**BRPM
Family
NDS # 901**

an ISO 9001 Certified Company



- **2 W RF OUTPUT**
- **HIGH SENSITIVITY**
- **HIGH DYNAMIC RANGE**
- **COMPACT SIZE**

This mini-repeater is intended for use in 900 MHz GSM mobile systems. It is especially advantageous, where the field strength is weak, or at other shaded areas like in large concrete buildings, tunnels, small valleys, etc. It is a cost effective solution to cover areas, which cannot be covered economically with large base stations. By using this repeater, the GSM operator is able to respond quickly and economically to the customers ever changing needs.

ELECTRICAL CHARACTERISTICS :

Frequency Band Uplink	890 – 915 MHz
Frequency Band Downlink	935 – 960 MHz
Frequency Bandwidth (Up/Downlink)	6 – 25 MHz (*)
Mode of Operation	band selective duplex
1 dB Compression	2 W (+ 33 dBm) typ.
Linear Output Power	+ 20 dBm @ < - 36 dBm IM products
ICP3	> + 44 dBm (+ 46 dBm typ.)
Nominal Gain	70 dB (*)
Gain Ripple	± 1.5 dB typical ± 3 dB max.
Gain Setting	70 to 40 dB in 2 dB steps
Input Noise Figure	< 7 dB
I/O Return Loss	≤ - 16 dB
RF Connectors	N – female
Supply Voltage	230 V / 50 Hz AC
Power Consumption	approx. 50 VA
Weight	approx. 10 kg
Operating temperature range	- 25 to + 55 °C
Outline	watertight compact AL housing

(*) Centre frequency and bandwidth can be specified in the whole GSM band.

Specifications are subject to change without notice.

OUTLINE DIMENSIONS (mm):

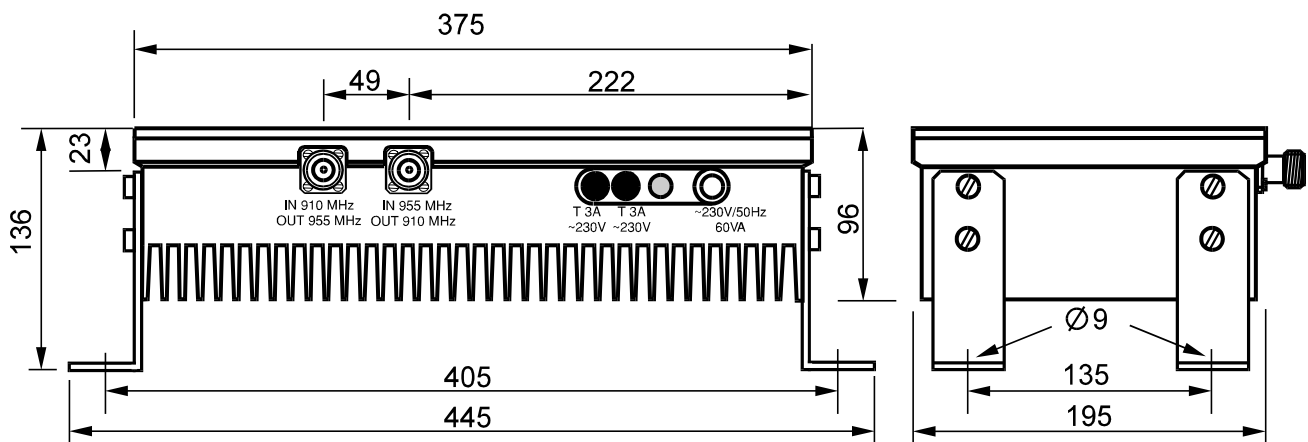

BONN Elektronik
RF Systems, Instruments and Components



Rudolf-Diesel-Str.18 · D-85521 Ottobrunn · Tel +49 (0)89/608 754-0 · Fax +49 (0)89/608 754-99
email: info@bonn-elektronik.com · home: www.bonn-elektronik.com